

High-Capacity AFC Systems

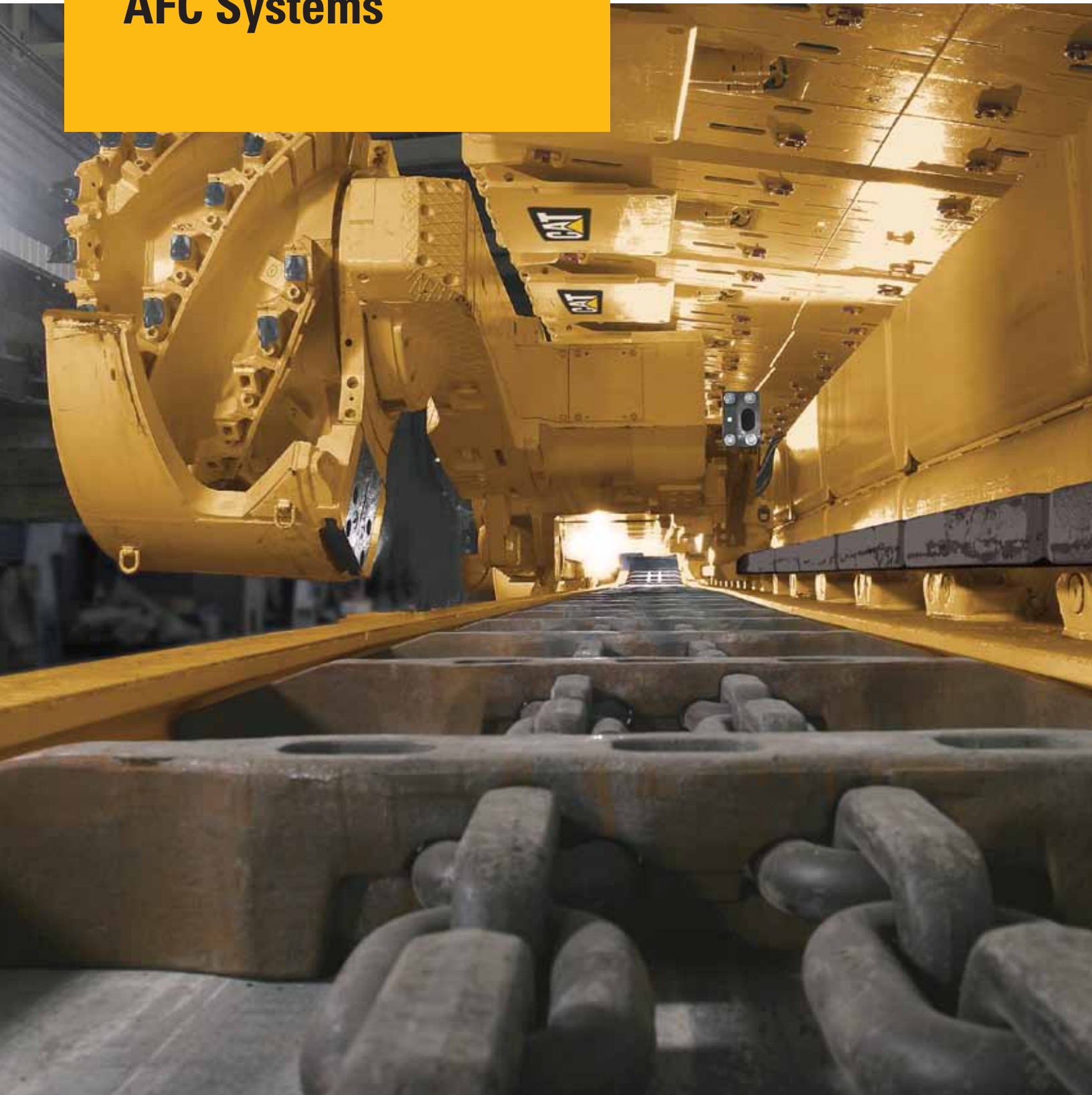



Moving Mountains

No matter how fast your shearer can cut, you can't keep cutting until you move the coal away from the face. Cat[®] Armored Face Conveyors (AFCs) are designed to keep things moving and to carry the maximum possible amount of coal smoothly away from the coalface. They are designed for high availability and economy in operation. They are easy to maintain and offer long service life and a great return on investment to mine operators.

Best in the Long Run

Cat AFCs excel through cutting-edge technology, quality, experience and superior product support. Of course, that's what any AFC manufacturer would like to promise. But we can. Our engineers invented the AFC in the early 1940s. Of the ten most productive mines in the world, eight use our face conveyors.

Several systems have successfully operated in 350 to 470 m (1,150 to 1,540 ft) faces producing up to 5 000 tonnes (5,512 tons) per hour and 10 million tonnes (11 million tons) per year. Our experience and track record are unmatched in super-long and high-capacity face conveyors.

And of course, Caterpillar – recognized as a world-leading developer and manufacturer of integrated longwall systems – has a long history of engineering

solutions that meet the needs of mine operators. That's why our longwall systems have been in service in all major coal-mining regions of the world for decades.



PF6 line pan

Meeting all Needs

From AFC tail drive to entry belt conveyor return end, Cat AFC systems are designed for a variety of performance requirements in low, medium and high seams, for short and long faces. Caterpillar meets the demand of today's high-capacity shearers and, of course, our own automated plow systems.

The PF Range

The line pan is the backbone of the AFC – literally. It not only conveys material from the face, but also acts as the guide rail for the shearer – with traction forces of up to 1 000 kN.

Caterpillar offers a range of line pans to suit different needs. These range from the PF3 for capacities of up to 1 300 tonnes (1,433 tons) per hour to the state-of-the-art PF6 with a capacity of 5 000 tonnes (5,512 tons) per hour.

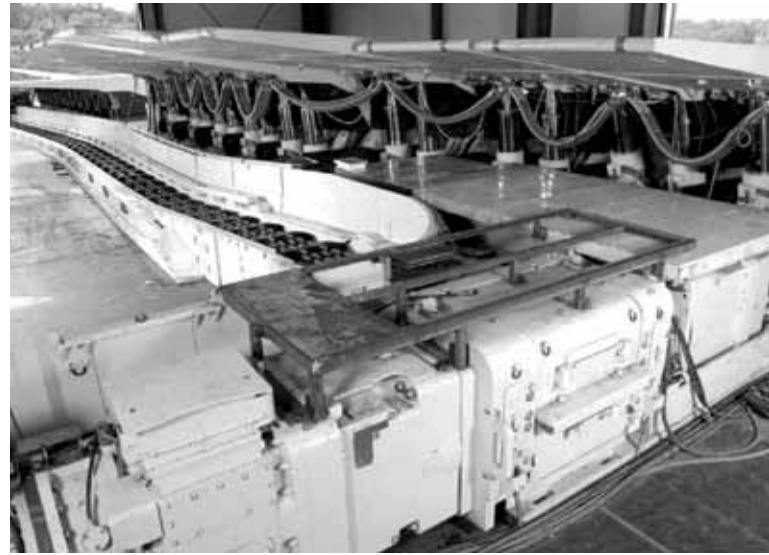

Compatibility testing of a complete Cat® longwall

Typical Technical Data AFC Line Pan					
Type	Width outside	Top plate thickness	Bottom plate thickness	Dogbone breaking force	Production average per hour
PF3	822 mm (32.4 in)	30 mm (1.2 in)	20 mm (0.8 in)	2 000 kN	1 300 tonnes (1,433 tons)
PF4	932 mm (36.7 in) 1 032 mm (40.6 in) 1 132 mm (44.6 in)	40 mm (1.6 in)	25 mm (1.0 in)	3 600 kN	1 800 tonnes (1,984 tons) 2 500 tonnes (2,756 tons) 3 500 tonnes (3,858 tons)
PF5	1 042 mm (41.0 in) 1 142 mm (45.0 in) 1 342 mm (52.8 in)	50 mm (2.0 in)	30 mm (1.2 in)	4 500 kN	2 500 tonnes (2,756 tons) 3 500 tonnes (3,858 tons) 5 000 tonnes (5,512 tons)
PF6	1 042 mm (41.0 in) 1 142 mm (45.0 in) 1 342 mm (52.8 in)	30+25 mm (1.2+1.0 in)	30 mm (1.2 in)	4 500 kN	2 500 tonnes (2,756 tons) 3 500 tonnes (3,858 tons) 5 000 tonnes (5,512 tons)

Typical Technical Data Stageloader Line Pan					
Type	Width outside	Top plate thickness	Bottom plate thickness	Dogbone breaking force	Production average per hour
PF4	932 mm (36.7 in) 1 132 mm (44.6 in) 1 332 mm (52.4 in)	40 mm (1.6 in)	25 mm (1.0 in)	3 600 kN	2 000 tonnes (2,205 tons) 3 800 tonnes (4,189 tons) 5 500 tonnes (6,063 tons)
PF6	1 342 mm (52.8 in) 1 542 mm (60.7 in) 1 742 mm (68.6 in)	50 mm (2.0 in)	30 mm (1.2 in)	4 500 kN	5 500 tonnes (6,063 tons) 6 200 tonnes (6,834 tons) 7 000 tonnes (7,716 tons)

Engineered to Perfection

There are many parts to an Armored Face Conveyor: shearer haulage system, drives, drive frames and sprockets, gearboxes, line pans, chain conveyors as well as entry conveyors and belt tailpieces. Each of these components has to be engineered to perfection, but also has to work together optimally with the other parts of the system.

Cat AFC components achieve this. Each is designed for powerful, reliable and economical operation with low maintenance over a long service life, promoting high productivity and delivering a great return on investment.

Shearer Haulage System

Cat rackbar shearer haulage systems meet the demands of today's high-performance shearers. We use design and material selection aimed at achieving maximum system availability, longest possible shearer, sprocket and trapping shoe life and on-system suitability for seam undulations.

As with all Cat products, these systems are the result of extensive R&D work and comprehensive laboratory and field testing. This ensures the optimum solution for haulage system and sprocket. This led to a unique design concept with optimized first/last tooth geometry rackbars available with pitches of 126 mm for medium-production and 146/151 mm for high-production shearers.

Drive Frames

Head-gate drive frames operated today are typical of the cross-frame design. Different capacity ratings are available depending on the total power required. The frame sides are manufactured from thick, solid plates to handle the high torque that may be generated and to ensure an adequate safety margin. Flange plates used to mount the transmission units enable easy rehanding.

Benefits

- Head drive does not cause a production bottleneck, maximum stability at maximum power, high power drives can be installed, upgrade normally possible, high AFC performance and availability.

3D-Simulation of a shearer on a Cat PF6 face conveyor at the head end under extreme bending

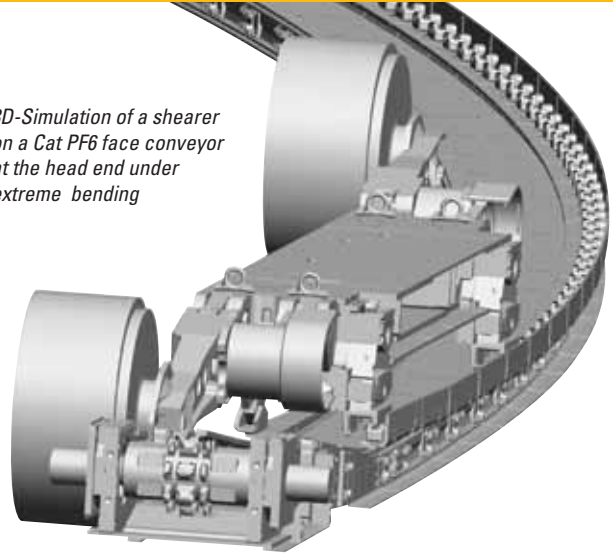

JumboTrack™ shearer haulage system

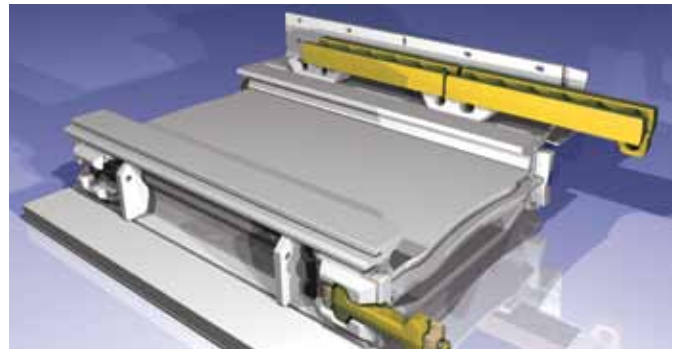

JumboTrack™ shearer haulage system



Crossframe

Drive Modules

The latest development is a drive frame with replaceable one-piece sprocket/shaft/bearing – a “drive module”. These are available in various sizes to suit individual power requirements, right up to 2 x 1 800 kW (2,412 hp) per drive. The drive module is identical for both main and tail drive. The drive frames are independent of the gearboxes used – flange plates and stub shafts are used for interfacing. Two hydraulic cylinders are integrated in the frames for disassembly of the drive module. These are powered by an external pump. There are similar designs for smaller drive frames.

Benefits

- Drive module can be replaced underground without disassembly of the gearboxes, drive units are available in different sizes and are independent of the gearbox used.

GR Sprocket

In contrast to conventional sprockets, the Cat GR sprocket is specially designed to spread the load across three teeth, ensuring maximum contact surface between the chain links and the sprocket teeth during operation. This results in lower wear and extended life of the sprocket and the chain.

Benefits

- More efficient power transmission with GR sprocket (97% vs. 93%), resulting in extended sprocket and chain life and less chain stretch

Tail Drives

Tail drives are normally the tensionable type, especially with long faces and/or high installed power. These have a stroke of 0.50 m for shorter, less powerful conveyors, and 1 m for long faces or conveyors with extremely high installed power. These allow control of 1 m and 2 m of slack chain respectively. An automated system keeps the AFC chain at optimum tension during operation.

Benefits

- Maximum chain life and minimum conveyor downtime for double cut

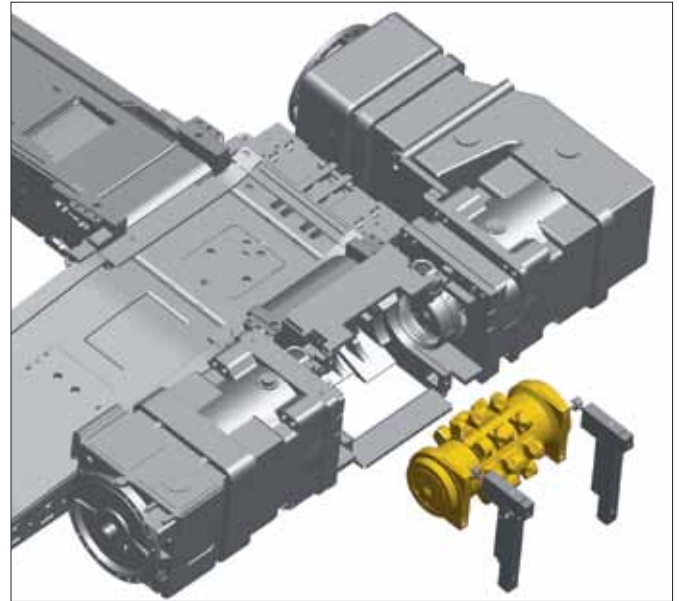

Sprocket Module

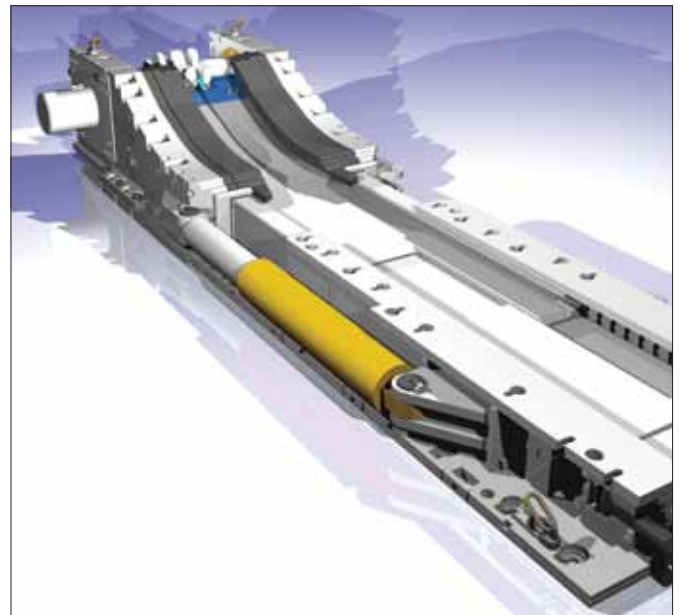

Tensionable tail drive

Gearboxes

Caterpillar offers gearbox solutions – simple planetary or bevel-spur gearboxes for low-power requirements and the installation of a clutch between motor and gearbox for medium-power installations.

The UEL gearbox – a planetary gearbox with an integrated clutch – is designed for higher-power requirements. This friction clutch is closed through face support hydraulic fluid. A hydraulic control system allows the clutch to be set to a certain torque.

Overload Protection

Overload protection is achieved by measuring the slip of each gearbox. In the event of a chain stall, both motors are switched off. Alternatively, the clutches at both drives can be opened using an optional drive control unit.

The Controlled Start Transmission (CST) drive system is designed for long, high-capacity faces. This drive system allows no-load motor startup, synchronized soft-start and heavy-load startup, as well as accurate load sharing and excellent overload protection.

Benefits

- Caterpillar has the right drive for your application ensuring smooth and safe operation of the conveyor with overload protection and a range of other safety features as required.

Chains

For years, we have been matching chain and sprocket design in high-performance face conveyors to achieve optimum performance and service life. This resulted in the 42 x 146 mm (1.70 x 5.70 in) combination chain, the standard chain for applications in the USA and Australia since 1991, and later in the 48 x 144/160 mm (1.90 x 5.70/6.30 in) chain for what was then the world's most powerful conveyor installation with 3 x 1 000 kW (3 x 1,341 hp) on a single longwall face conveyor. The latest development is the Cat PowerChain. It is available in sizes 34, 42 and 52. Size 52 is designed to be used with up to 1 200 kW (3 x 1,608 hp), with a chain suitable for up to 1 800 kW (3 x 2,412 hp) under development.



Cat intelligent CST drive system for high-capacity face conveyors

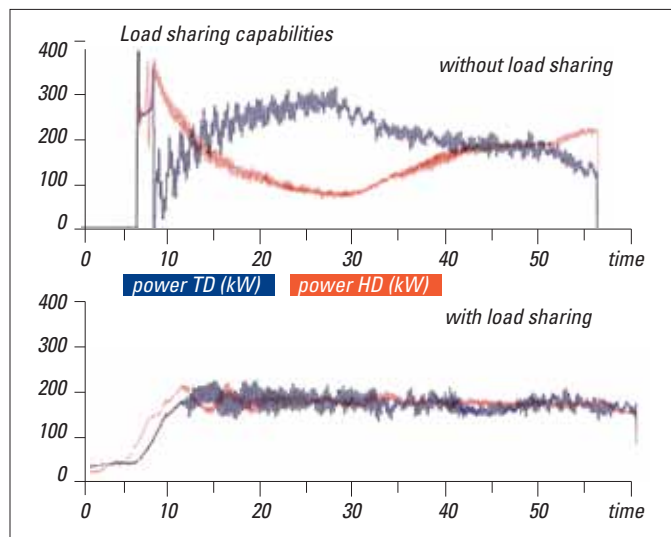

TD = Tail Drive HD = Head Drive

Trial run of a complete system



PowerChain

The wide, arc-shaped cross-section of the vertical links allows a low-profile line pan and the special shape of the horizontal link provides a large running surface where required, drastically reducing surface pressure and chain-joint wear. The method for attaching the flight bar is patented.

The PowerChain 42 x 140 mm (1.7 x 5.5 in) has a breaking force of 2 370 kN, the PowerChain 52 x 175 mm (2.0 x 6.9 in) of 3 610 kN.

Benefits

- Faster removal of mined coal by providing high-reliability, high-availability transportation with design features ensuring low wear and long service life, greater permissible elongation of chain compared to round link

Entry Conveyors and Belt Tailpieces

Entry conveyor or stageloaader pans are normally of the same type as used in the face. These are normally wider than the AFC. While the return roller is integrated into the cross frame design, the head drive frame of the stageloaader is tensionable using hydraulic cylinders.

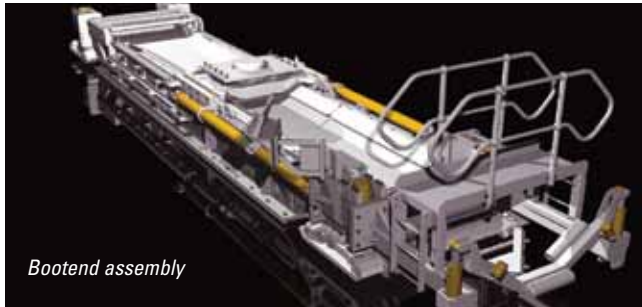

Bootend assembly

The crusher, usually an impact roller, is integrated into the stageloaader design. The following goose-neck lifts the stageloaader discharge over the belt tail piece. Belt tail pieces are available in fixed-, skid- or crawler-mounted versions with an overlap of up to 3.5 m (11.5 ft), all equipped with self-cleaning return drums. The operator can use any specified belt width in this tailor-made equipment.



PowerChain and sprocket in use with a Cat beam stageloaader



PowerChain inside a Cat BSL in the crusher area

Benefits

Stageloaader and crusher completely matched to AFC, both with higher capacity to prevent bottlenecks; tailor-made belt tailpiece for required capacity and belt dimensions, allowing BTP to handle longitudinal and lateral entry gradients; automated chain tensioning system.

Complete Cat entry conveyor or beam stage loaader (BSL) including crusher and belt tail piece



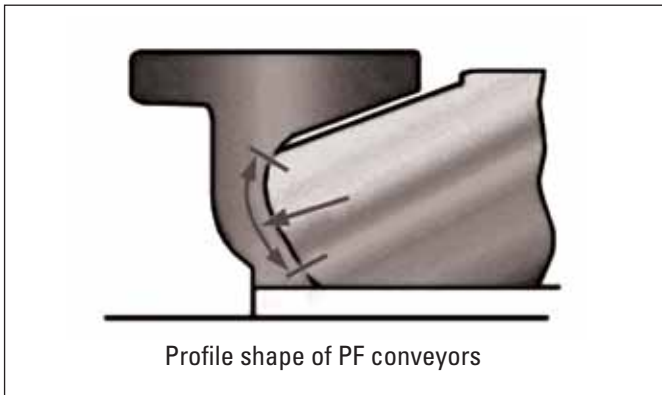

Line Pans for Every Need

Rolled steel is smoother, stronger and harder-wearing than a casting and generates less friction and noise. That's why Caterpillar has focused on rolled steel designs for line pans. All aspects of the line pans have been engineered with reliability, productivity and serviceability in mind.

Maximum Contact

The profiles are designed to maximize the contact area between the flight bar and the profile, thus minimizing contact pressure during operation.

- Minimizes friction, reduces power requirements for the face conveyor and results in longer service life of the flights and profiles

Rolled Steel

Rolled material has a smoother surface than castings. The material shows maximum wear resistance after initial material conveyance.

- Lower friction and longer service life for wear parts.
Up to 10 million tonnes (11 million tons) under normal conditions and up to 20 million tonnes (22 million tons) under favorable conditions.



Compatibility testing

Safe Dogbone Technology

The forged dogbone pocket and the designed breaking force of up to 4 500 kN guarantee safe operation of the conveyor at all times. Sophisticated design has been further optimized, ensuring greater tensile strength to reduce stress spikes and ensure perfect protection of the dogbone pocket and the pan itself in the event of an overload.

- Longer service life of dogbone pockets, no damage to conveyor or dogbone housing as the dogbone always breaks first



Dogbone

Convex/Concave Pan Ends

Cat line pans feature convex/concave pan ends that ensure reduced noise levels. Our line pans are suitable for bi-directional operation.

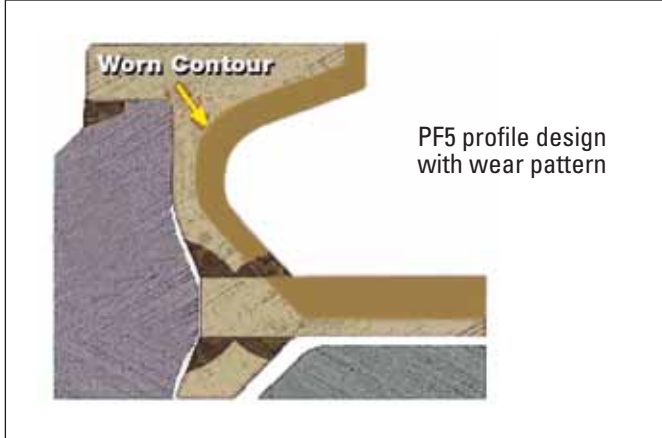

Vertical bending capability of Cat face conveyor systems

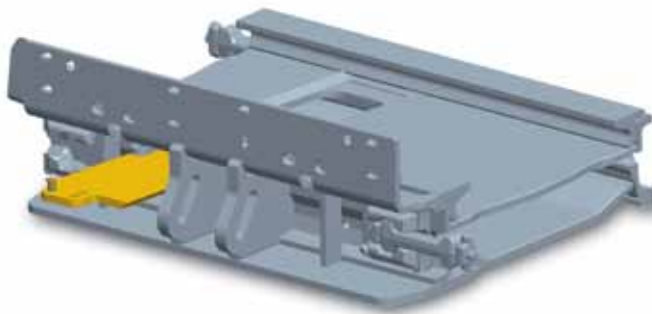

Welds without Wear

Cat PF line pans have a rolled profile design. Each of the identical profiles are attached with two welds to the top plate of chosen length and width. This results in great flexibility in pan design. Only one of the welds is located in the wear area of the line pan in the top strand.

- High stability of the pan ensured by three welds even when the top plate is totally worn out

Wear-resistant Top Plate

The top plate is made of wear-resistant material. The thickness varies from 30 mm (1.2 in) (PF3) to 50 mm (2.0 in) (PF5).

- Long service life with matched profile type end

Flexibility

The line pans are designed to allow deflection between individual line pans of $\pm 6^\circ$ vertically and $0.8\text{--}1.2^\circ$ horizontally.

- Increased flexibility, adaptation to undulating seams, short snake sections possible

Safe Transfer of Transverse Forces

Transverse forces are transferred through the top plate to the relay bar arrangement.

- High pan stability, even for high-reaction forces; safe operation; low noise; minimum maintenance; full reversibility

Inspection Doors

A sliding inspection door typically installed in every 6th pan and every special pan allows access to the bottom race of the chain conveyor. The integrated drawer guide ensures safe seating of the doors. The inspection door can be removed from gob or face side.

- Easy access to bottom chain, minimum downtime during maintenance or repair

PF6 – the State-of-the-Art Line Pan

Wear is the weak point in line pan design. Hauling millions of tonnes of coal away from the longwall is clearly going to result in high levels of wear. Back in 2002, we decided to try something revolutionary. A group of experts from different countries with many years of experience on various conveyor types was brought together to create a new type of pan that would combine the benefits of rolled and cast line pans to provide an optimum solution to mining industry needs.

The First to Really Last and Last

The team developed an innovative pan design meeting all the requirements regarding quality, resistance to wear and conveying capacity in ultra-long panels. The result is the PF6, a hybrid pan that addresses the weakest point in pan design: wear. The simple solution was to make the parts subject to the most wear replaceable.

With its patented trough concept and extremely rugged pan design, the PF6 is particularly suitable for applications in longwalls with extended face length and for panels with coal reserves of 10 million tonnes (11 million tons) and up.

Nothing Proves Success like Success

The success of the project is clear from sales: By the end of 2011, over 15,000 PF6 line pans had been manufactured as more and more operators become convinced of the benefits of the revolutionary PF6 concept.

Separation of Wear Parts and Structural Parts

The smart and totally new idea of splitting up the different functional areas in the PF6 allows the separation of wear parts and structural parts. Very hard, wear-resistant materials are used for wear parts, while the structural parts are made of high-strength steel.

- Ability to replace wear parts, substantially longer service life, lower overall pan wear

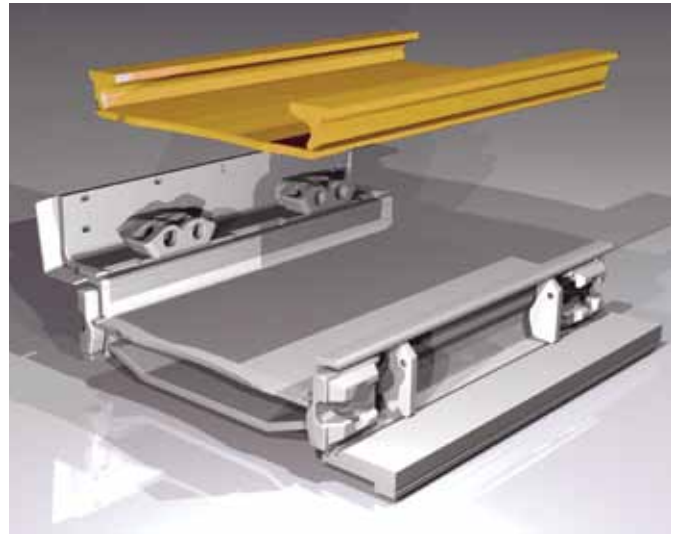

PF6 pan with replaceable top trough



Complete Cat longwall with high-capacity AFC system

Optimized Contact Surfaces

The special shaping of the bottom race – which almost doubles the contact surface – reduces flightbar shoulder wear and substantially reduces friction. The curved transition at the pan ends greatly reduces noise during operation of the chain conveyor.

- Minimal friction and power loss, longer flightbar and profile service life, lower noise

Maximum Pan Stability

The frame of the pan consists of two C profiles connected by a baseplate. Two tried-and-tested PF5 profiles are welded to the bottom plate of the top trough and then welded or bolted to the pan base. This allows problem-free replacement of worn top troughs.

Pan sections are connected by dogbones inserted into pockets in the C profiles. These are designed to engage exactly, providing optimal absorption of vertical and horizontal reaction forces. This ensures reliable transmission of high lateral forces, such as from roof supports. All forces were calculated and the pan was successfully tested with the frame of the PF6 pan only.

- High stability and positive force transmission, easy maintenance, trouble-free operation in both directions

Customization

Whether the design of the cover plates or the design of spill plates for hoses and cables, all components of the PF6 are individually designed to meet our customers' requirements.

- Optimal adaptation to local conditions, perfect functioning with various shearer haulage systems

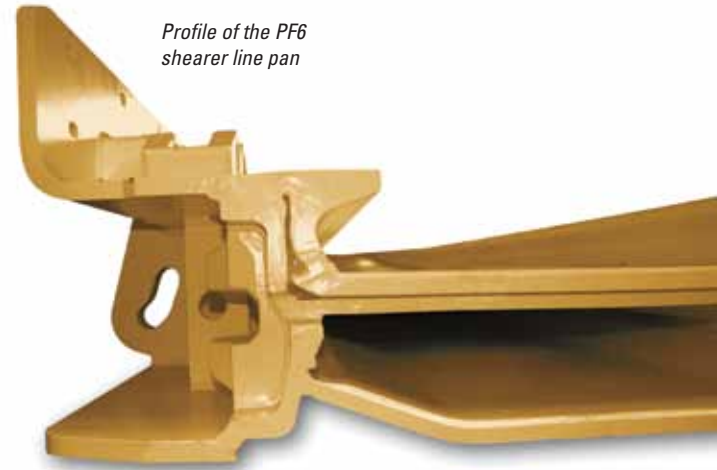

Profile of the PF6 shearer line pan



Simulation of a hump during a compatibility test with a shearer

Rolled Steel Surfaces and Robot Welding

Extremely smooth rolled-steel surfaces ensure minimum friction and power loss. Robot welding ensures standardized welds that can be removed automatically when the top race is worn, allowing replacement of the trough. This innovation is expected to increase the service life of the substructure by a factor of 3.



- Longer service life, simple replacement of wear parts, lower friction and power loss.

High-Capacity AFC Systems

For more complete information on Cat products, dealer services, and industry solutions, visit us on the web at mining.cat.com and www.cat.com

© 2011 Caterpillar Inc.
All rights reserved

AEXQ0604-01

Materials and specifications are subject to change without notice. Featured machines in photos may include additional equipment. See your Cat dealer for available options.

CAT, CATERPILLAR, their respective logos, "Caterpillar Yellow" and the "Power Edge" trade dress, as well as corporate and product identity used herein, are trademarks of Caterpillar and may not be used without permission.

